

ASSEMBLY INSTRUCTIONS

PARTS LIST:

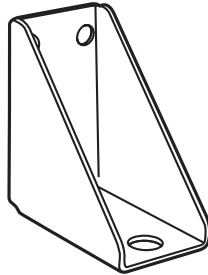

4 X C1 BOLTS

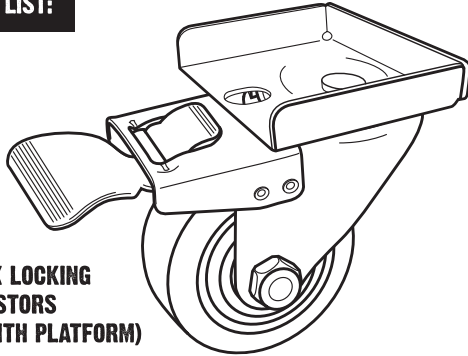

4 X C1 NUTS



8 X B1 BOLTS



8 X B1 NUTS



8 X B1 WASHERS

TOOLS REQUIRED:

PHILIPS/FLAT HEAD SCREW DRIVER, 2 X SHIFTING SPANNER/WRENCHES (OR BLUNT NOSE PLIERS) AND/OR SOCKET WRENCH SET

WARNING:

DO NOT USE IF ANY PARTS ARE MISSING OR BROKEN.

PLEASE NOTE:

RACK IT WORKBENCH CASTORS ARE DESIGNED FOR USE WITH THE RACK IT WORKBENCH UNIT ONLY AND CANNOT BE USED WITH OTHER ASSEMBLED RACK IT UNITS.

Steps:

1. Assemble Rack It Workbench
2. Lay assembled workbench frame on its side
3. Engage the brakes on all 4 Castors to avoid the Castor swivelling when installing.
4. Position Angled Brace to upper platform of Rack It Upright Foot ensuring the large single hole in Upright Foot lines up with large single hole on the Angled Brace.
5. Place large C1 bolt through all three holes (from the bottom) then tighten using C1 Nut. Be sure not to over tighten. **(IMAGE 1)**
6. Once in position, Use B1 Bolt and Nuts to secure the remaining two holes in the Angle Brace to the Upright through the V shaped slots. Use B1 Washer on the outside. **(IMAGE 2)**
7. Repeat steps 3-5 on other feet. Double check all nuts on all Castors are tightened firmly.
8. Carefully lift and place workbench upright releasing the brakes of each castor.
9. Reattached workbench top.

IMAGE 1

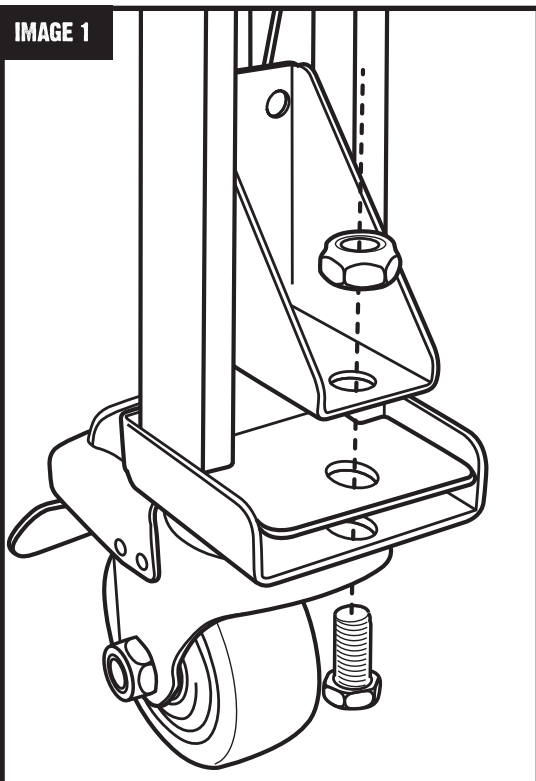

IMAGE 2

