

ITEM CODE: 01905

VERY IMPORTANT

Please read the instructions completely before commencing assembly. Unpack the unit and verify that you have all parts listed below. Assemble the unit on a solid, level surface.

SAFETY TIP

When assembling or installing this product wear protective gloves and eyewear

PARTS LIST

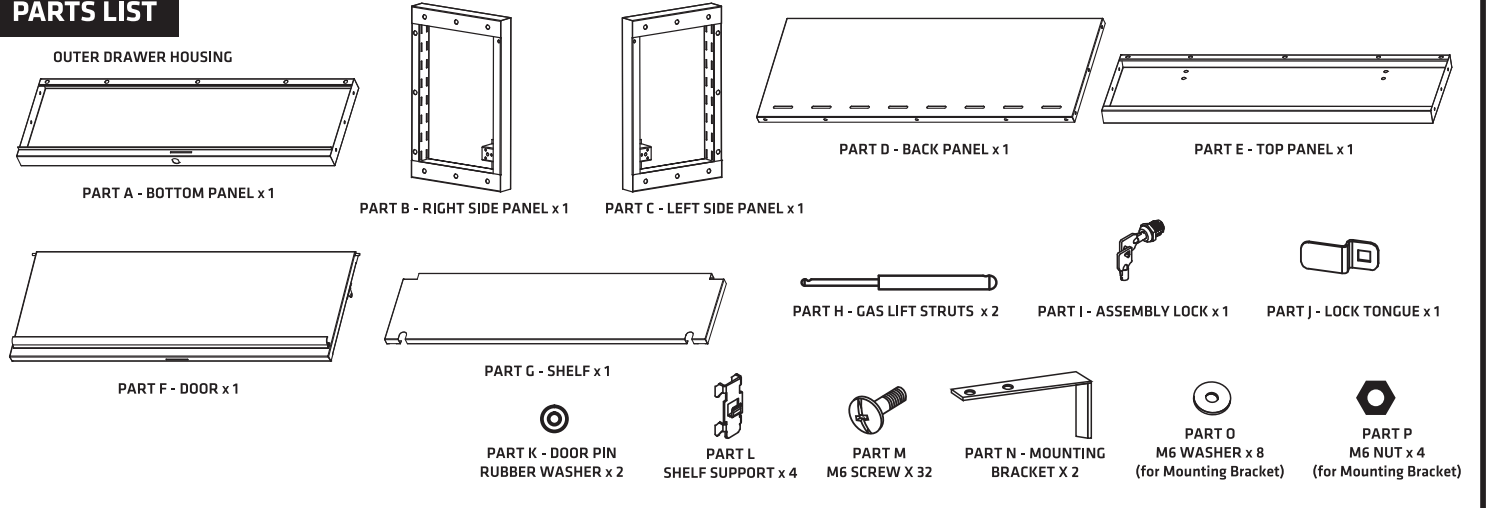

PLEASE NOTE: If using an electric screwdriver only loosely tighten screws, finish tightening with hand screwdriver to avoid damage.



STEP 1

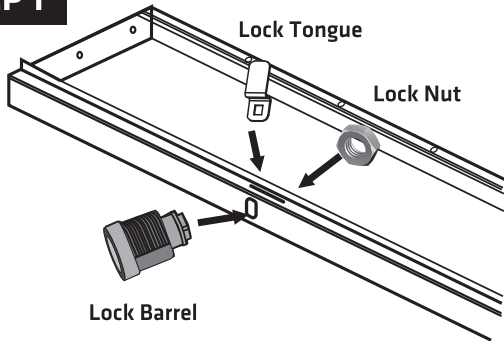

Fit Tongue onto square lock spindle

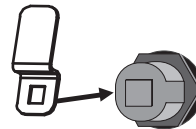

Lock Correctly installed. (Locked Position)

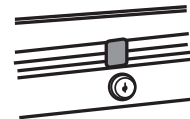

Locked



Unlocked

FIX LOCK TO BOTTOM PANEL

Fit Door Lock (I) to Bottom Panel (A)

1. Remove Lock Nut and fit Lock through hole in Bottom panel. Start the lock nut on the thread.
2. Insert Lock Tongue (J) through the slot in Bottom Panel and engage Tongue to the Lock mechanism by fitting the Tongue onto the square Lock spindle.
3. Finish tightening the Locking Nut on the Lock Barrel.
4. Test with the Key to make sure mechanism is working correctly. Remove Key and store safely.

STEP 2

Screw holes at the back of Bottom Panel

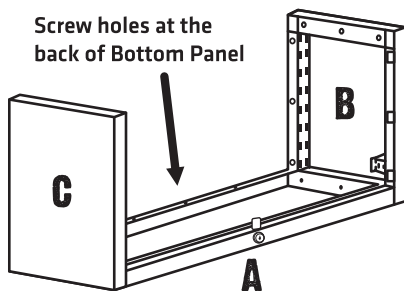

FIX LOCK TO BOTTOM PANEL

Place Bottom panel (A) on flat surface and screw fix Right Side Panel (B). Screw Fix the Left Side Panel (C).

STEP 3

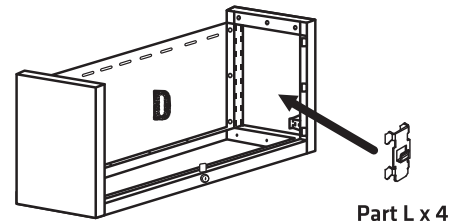

Part L x 4

FIX BACK PANEL & SHELF SUPPORTS

1. Screw fix Back Panel (D) onto the partially assembled unit.
2. Fit the Shelf Supports (L) x 4 into the vertical tracks located in each corner of the unit. Make sure Shelf Supports are located at the same height for your preferred shelf position. (Count the number of track slots from the bottom so you can easily position the Shelf Supports.)

ITEM CODE: 01905

VERY IMPORTANT

Please read the instructions completely before commencing assembly. Unpack the unit and verify that you have all parts listed below. Assemble the unit on a solid, level surface.

SAFETY TIP

When assembling or installing this product wear protective gloves and eyewear

STEP 4

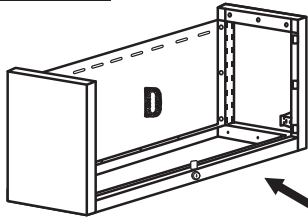

Note: The Shelf must be fitted with circular cut-outs facing the front. This allows for fitting of the Gas Struts.



FIT SHELF

Fit the Shelf (G) onto the Shelf Supports.

Important: The Shelf must be fitted PRIOR to placing Top Panel (E) onto the Overhead Cabinet. If you do not follow this step the shelf will not fit a fully assembled unit.

STEP 5

Make sure the 2 sets of pre-punched holes are towards the back

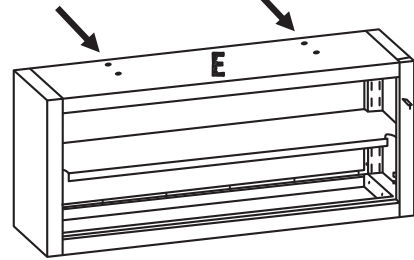

FIX LOCK TO BOTTOM PANEL

Once the Shelf is fitted, screw fix Top Panel (E) onto the partially assembled Unit.

STEP 6



HINGE PIN

LEFT Hinge Pin

RIGHT Hinge Pin



Fit Washer (J) on the Pin

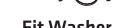

Fit Washer (J) on the Pin

FIT DOOR

The Door (F) is fitted with 2 spring loaded hinges. Simply depress the lever on the hinge to retract the Hinge Pin.

1. Fix the supplied Rubber Washer (K) on the Hinge Pin so it sits between the door frame and the cabinet.
2. The Left and Right Hinge Pins are located on the inside of the door. Retract the pin far enough to slip it into the pre-drilled holes in the Cabinet frame.

STEP 7

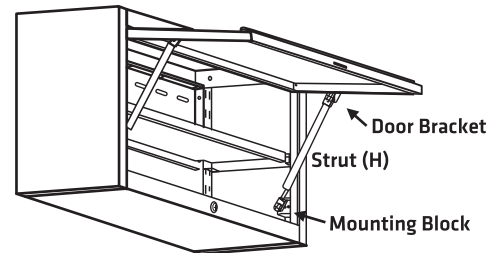

FIX THE GAS STRUTS

Attach the Gas Struts (H) x 2 to the Door and to the inside of the Cabinet.

1. Fit Strut to pre-fitted bracket on the Door.
2. Fit Strut to mounting block inside the cabinet

STEP 8

MOUNTING BRACKET (N) x 2

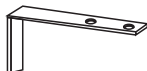

M6 WASHER (O) x 8

M6 NUT (P) x 4

M6 BOLT (M) x 4

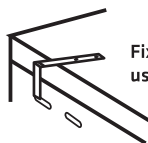

Fix each Mounting Bracket using 2 sets of Nut, Bolt and Washer.

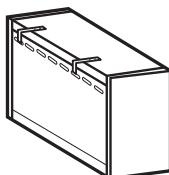

FIX THE MOUNTING BRACKETS

The Top Panel (E) has 2 sets of pre-punched holes to allow easy fixing of the nuts, bolts and washers for the Mounting Brackets (N).

STEP 8

FRONT VIEW



BACK VIEW



FIT THE ASSEMBLED UNIT ONTO YOUR RACK IT BEAMS

Simply hand the assembled Cabinet over the Rack It Beam. We recommend hanging the Cabinet so that it hangs off the Top Beam and rests on a Lower Beam.