

**TOOLS REQUIRED:**

- RUBBER Mallet
- #2 PHILLIPS HEAD SCREWDRIVER
- 10MM SPANNER OR SHIFTER

**WARNING:** HANDLE CUT METAL EDGES CAREFULLY

ITEM CODE: 01921

**VERY IMPORTANT**

Please read the instructions completely before commencing assembly. Unpack the unit and verify that you have all parts listed below. Assemble the unit on a solid, level surface.

**SAFETY TIP**

When assembling or installing this product wear protective gloves and eyewear

**PARTS LIST**

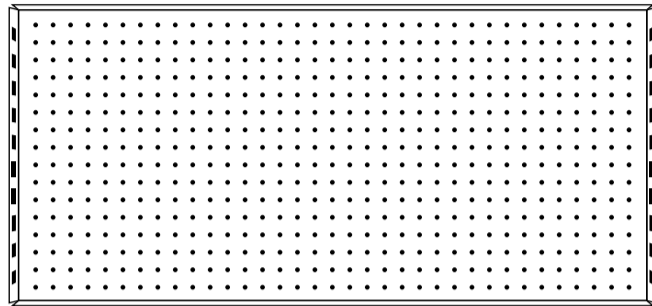

Peg Board x1

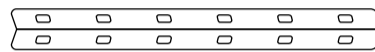

Angled Bracket x1

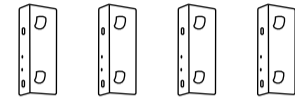

Brackets x4

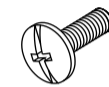

Nuts x6



Bolts x6

**PLEASE NOTE:** If using an electric screwdriver only loosely tighten screws, finish tightening with hand screwdriver to avoid damage.



**SINGLE PEG BOARD CONFIGURATION** (Recommend 2 person build)

**STEP 1A**

**Note:** Back of Peg Board

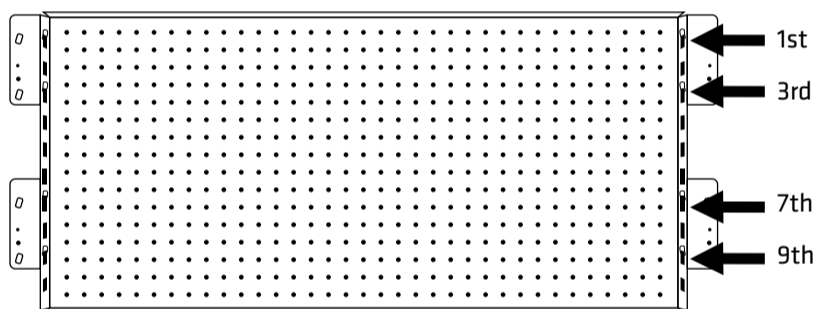

**ALL FOUR BRACKETS ARE TO BE ATTACHED ONTO THE PEG BOARD PRIOR TO MOUNTING ONTO THE RACK IT UPRIGHTS**

1. Top brackets to be inserted into the 1st and 3rd hole positions.
2. Bottom brackets to be inserted into the 7th and 9th hole positions.

**STEP 2A**

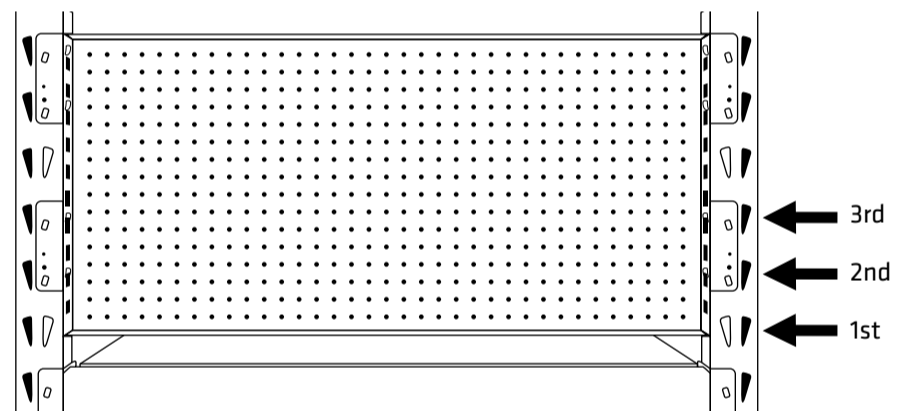

**WHILE HOLDING THE FOUR BRACKETS, MOUNT THE PEG BOARD ONTO THE UPRIGHTS**

1. For best results attach the lower Peg Board Brackets into the 2nd and 3rd upright slots above a Workbench Shelf.

**STEP 3A**

**INSERT SAFETY PINS INTO ALL 4 BRACKETS TO ENSURE THE PEG BOARD IS SECURED**

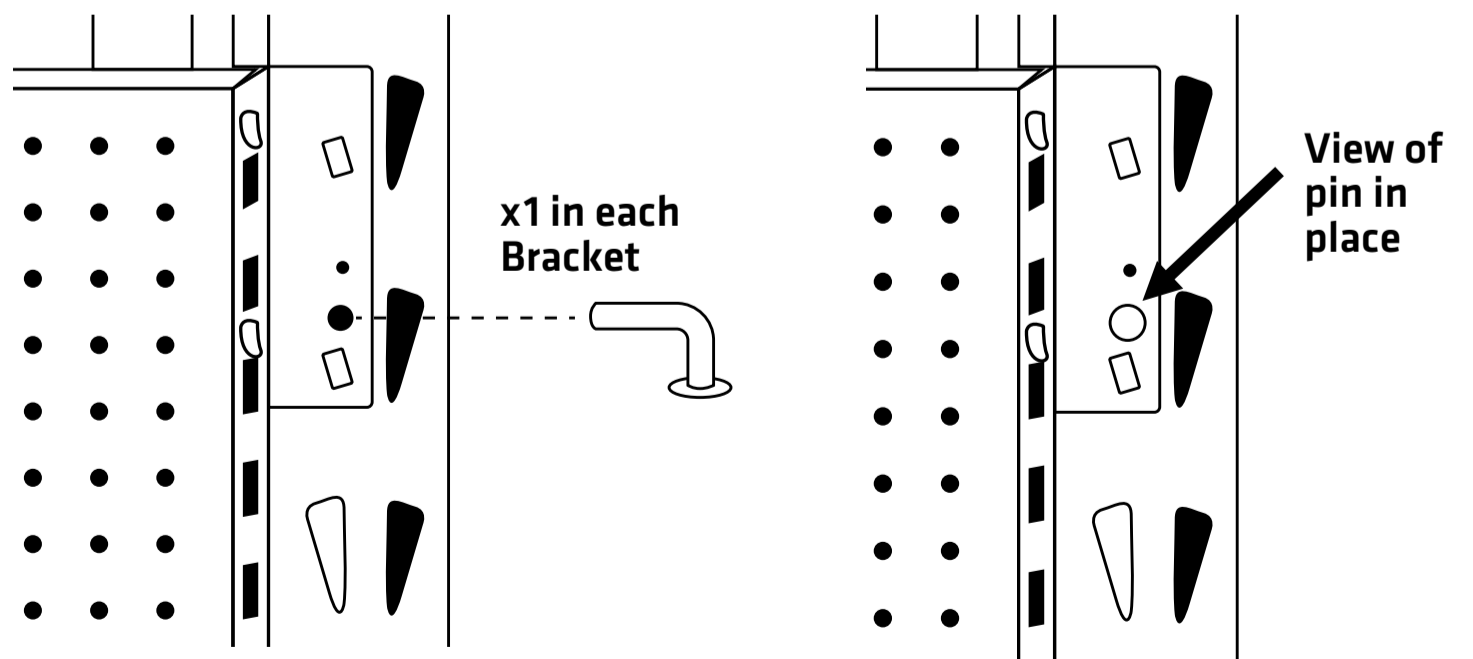

x1 in each Bracket

View of pin in place

**TOOLS REQUIRED:**

- RUBBER Mallet
- #2 PHILLIPS HEAD SCREWDRIVER
- 10MM SPANNER OR SHIFTER

**WARNING:** HANDLE CUT METAL EDGES CAREFULLY

ITEM CODE: 01921

**PLEASE NOTE:** If using an electric screwdriver only loosely tighten screws, finish tightening with hand screwdriver to avoid damage.



### STACKED PEG BOARD (2 SINGLE PEG BOARDS) (Recommend 2 person build)

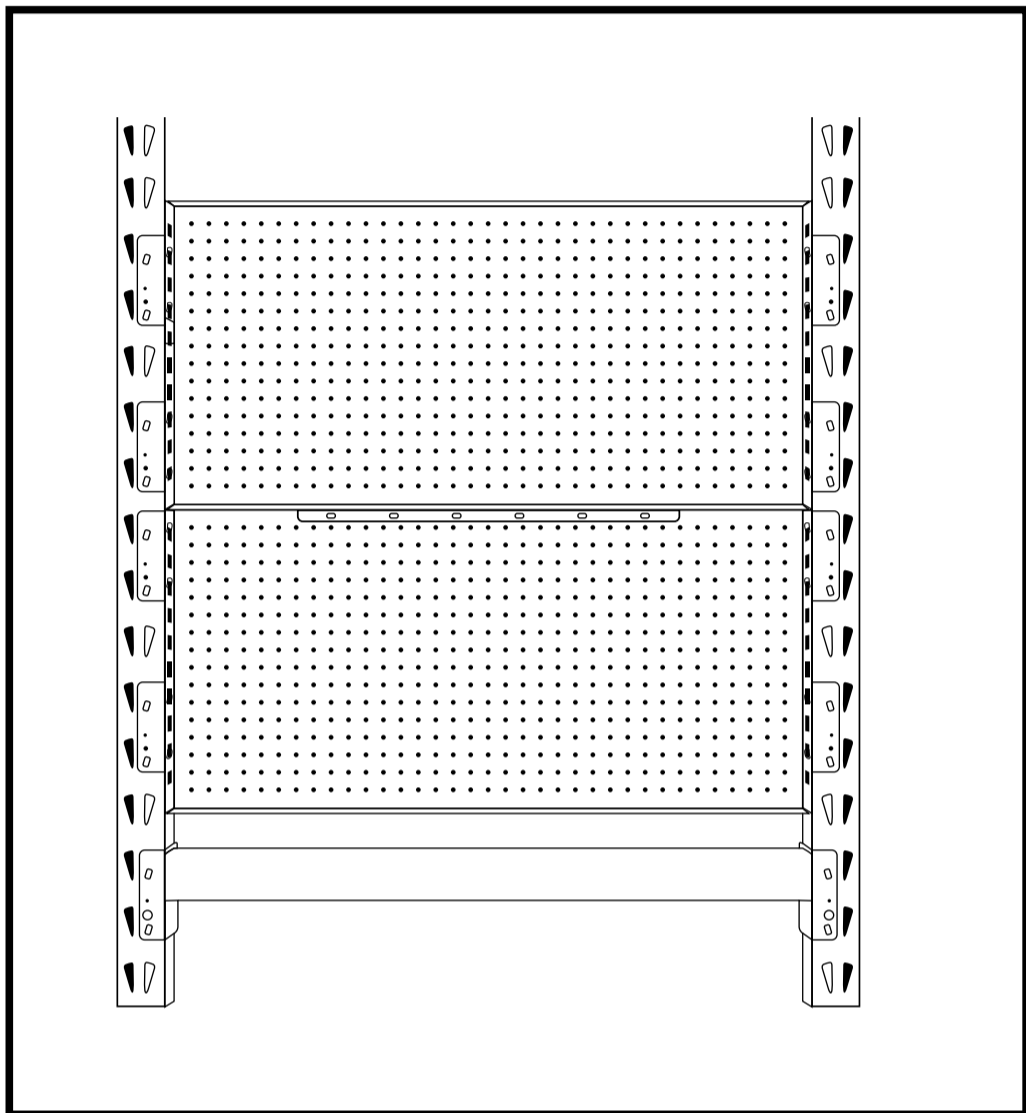

#### STEP 1B

Note: Back of Peg Board

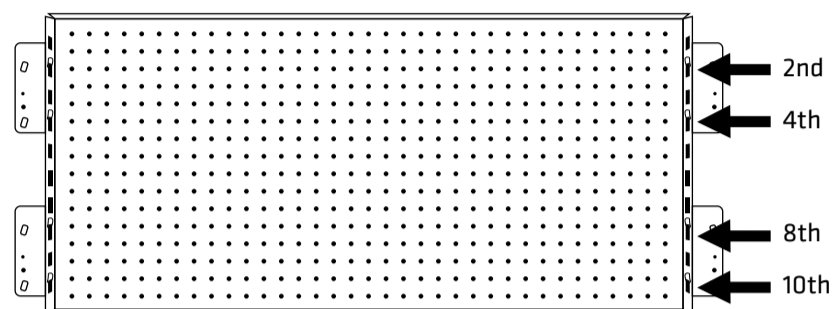

**REPEAT SINGLE PEG BOARD INSTALLATION TO CREATE A SECOND PEG BOARD. HOWEVER, THIS TIME, INSERT BRACKETS INTO THE HOLE POSITIONS ABOVE.**

1. Top bracket to be inserted into the 2nd and 4th hole positions.
2. Bottom bracket to be inserted into the 8th and 10th hole positions.

#### STEP 2B

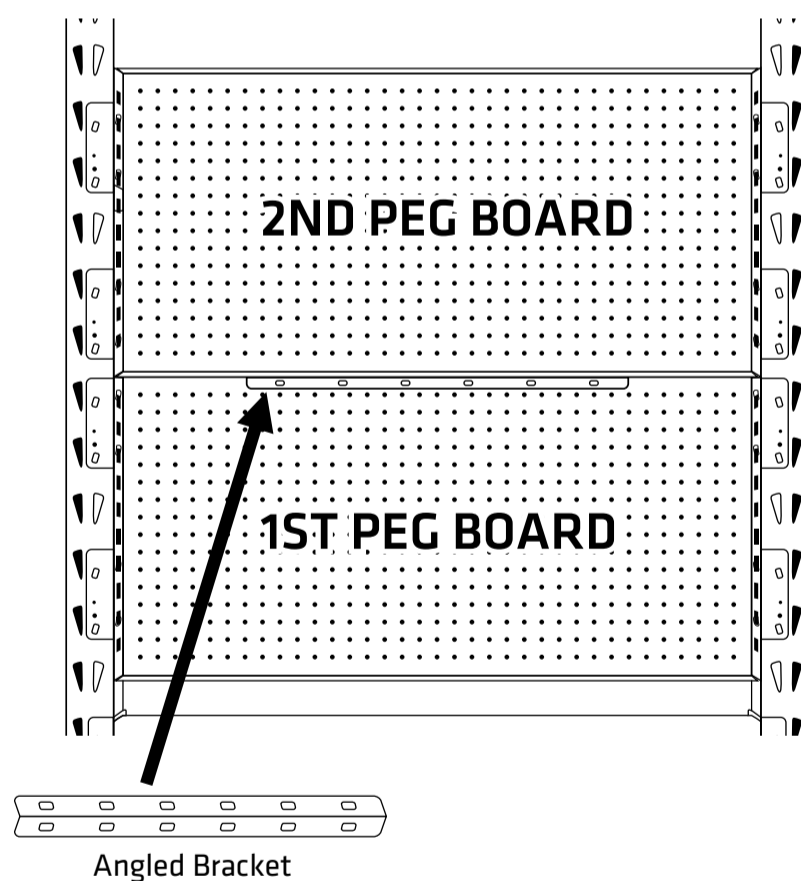

1. To add an additional Peg Board on top, attach the Peg Board into the next available slot on the Upright.
2. Once Peg Board is in place, slot the Angled Bracket in between the two Peg Boards, align the bolt holes and secure with supplied Nuts and Bolts.

ITEM CODE: 01921

**TOOLS REQUIRED:**

- RUBBER Mallet
- #2 PHILLIPS HEAD SCREWDRIVER
- 10MM SPANNER OR SHIFTER

**WARNING:** HANDLE CUT METAL EDGES CAREFULLY

**PLEASE NOTE:** If using an electric screwdriver only loosely tighten screws, finish tightening with hand screwdriver to avoid damage.



### SIDE BY SIDE PEG BOARD (2 SINGLE PEG BOARDS) (Recommend 2 person build)

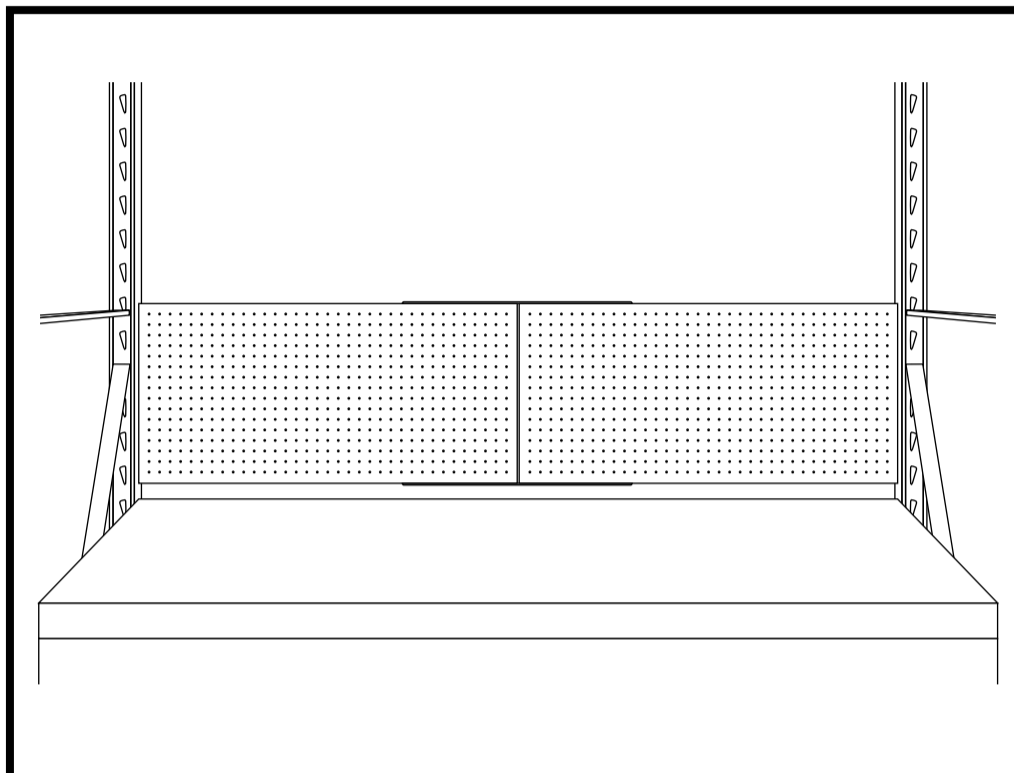

#### STEP 1C

Note: Back of Peg Board

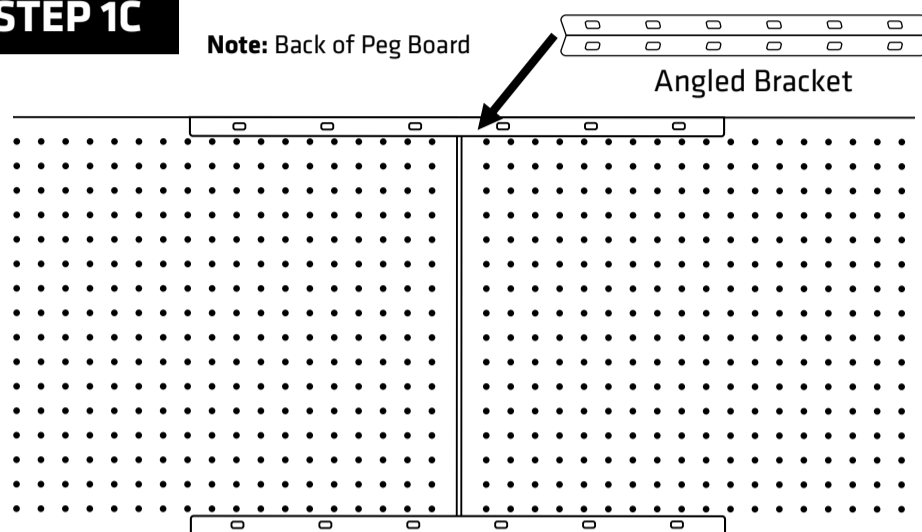

#### BOTH PEG BOARD PANELS SIDE BY SIDE

Align the angled bracket with the holes on top and bottom edges.

#### STEP 2C

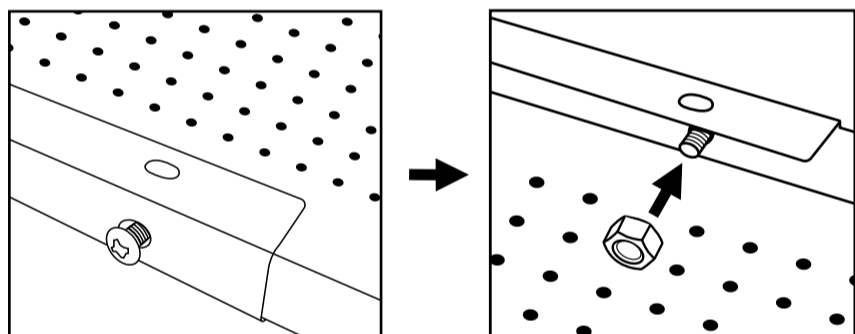

#### INSERT A BOLT THROUGH THE ANGLED BRACKET AND THE PEG BOARD AND TIGHTEN WITH A NUT

Repeat this for all 6 holes on both Brackets.  
(3 holes either side of the centre)

#### STEP 3C

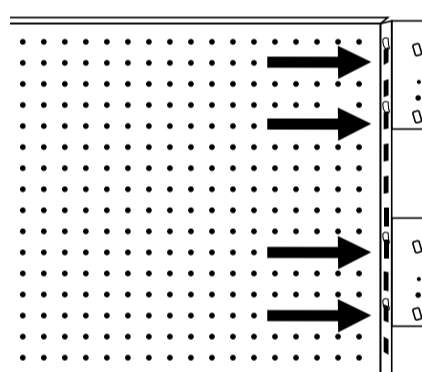

Top brackets to be inserted into the 1st and 3rd hole positions.

Bottom brackets to be inserted into the 7th and 9th hole positions.

#### ATTACH TWO BRACKETS ONTO EACH SIDE OF THE JOINED PEG BOARD PRIOR TO MOUNTING ONTO THE RACK IT UPRIGHTS

#### STEP 4C

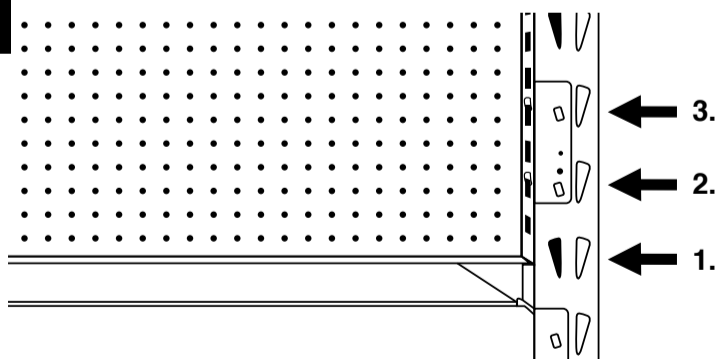

#### WHILE HOLDING THE FOUR BRACKETS, MOUNT THE PEG BOARD ONTO THE UPRIGHTS

For best results attach the Peg Board onto the Upright into the 2nd and 3rd slots above a Workbench Shelf.

#### STEP 5C

#### INSERT SAFETY PINS INTO ALL 4 BRACKETS TO ENSURE THE PEG BOARD IS SECURED

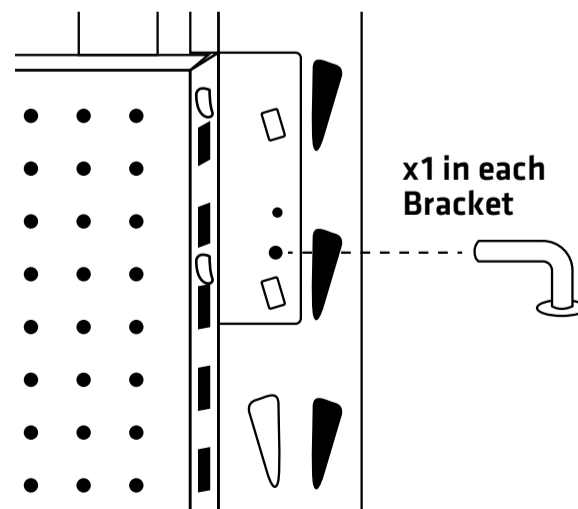

x1 in each Bracket

# RACK IT

1000KG

# PEG BOARD

## ASSEMBLY INSTRUCTIONS

ITEM CODE: 01921

### TOOLS REQUIRED:

RUBBER Mallet  
#2 PHILLIPS HEAD SCREWDRIVER  
10MM SPANNER OR SHIFTER

**WARNING:** HANDLE CUT METAL EDGES CAREFULLY

**PLEASE NOTE:** If using an electric screwdriver only loosely tighten screws, finish tightening with hand screwdriver to avoid damage.



## 2x2 PEG BOARD (4 SINGLE PEG BOARDS) (Recommend 2 person build)

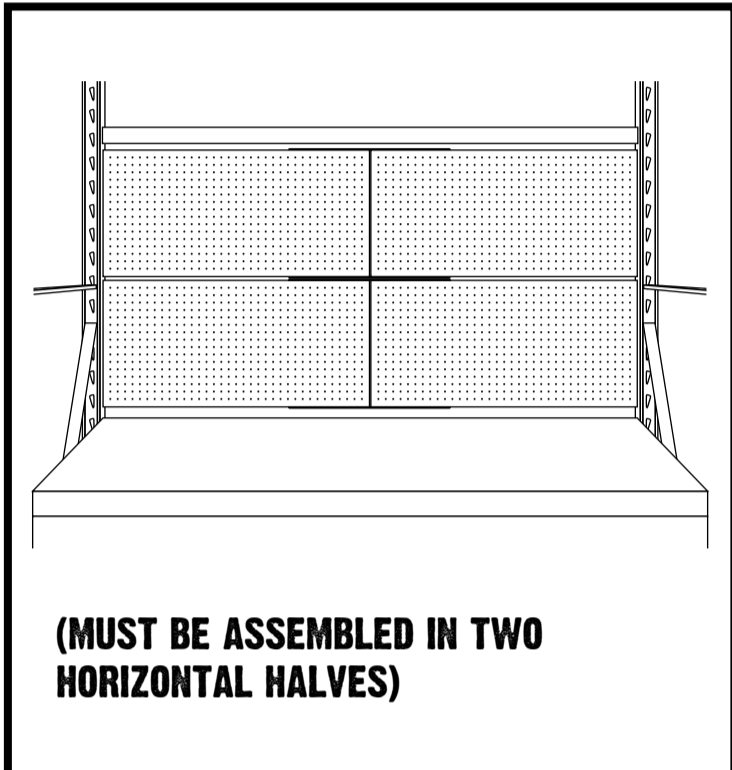

**(MUST BE ASSEMBLED IN TWO HORIZONTAL HALVES)**

### STEP 1D

#### ASSEMBLE BOTTOM HALF OF PEGBOARD

Follow Steps 1C to 5C, however do not attach the top Angled Bracket until Step 6D.

### STEP 2D

Note: Back of Peg Board

Angled Bracket

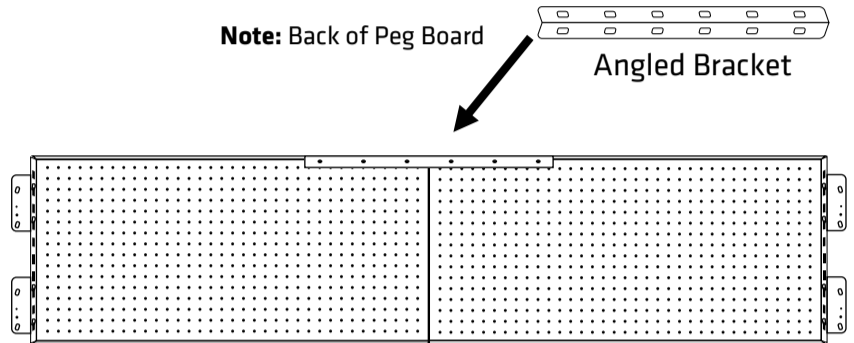

#### ASSEMBLE TOP HALF OF PEG BOARD

Align the Angled Bracket with the holes on top edge of the Peg Board and secure with Bolts and Nuts.

### STEP 3D

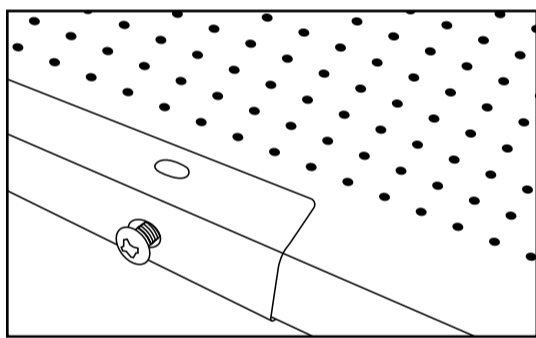

#### INSERT A BOLT THROUGH THE ANGLED BRACKET AND THE PEG BOARD AND TIGHTEN WITH A NUT.

Repeat this for all 6 holes on the Top Bracket.  
(3 holes either side of the center)

### STEP 4D

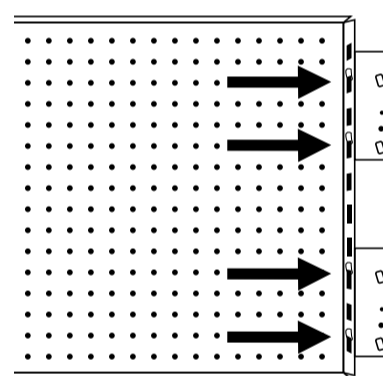

Top brackets to be inserted into the 2nd and 4th hole positions.

Bottom brackets to be inserted into the 8th and 10th hole positions.

#### ATTACH TWO BRACKETS ONTO EACH SIDE OF THE JOINED PEG BOARD PRIOR TO MOUNTING ONTO THE RACK IT UPRIGHTS

### STEP 5D

**WHILE HOLDING ON TO ALL FOUR BRACKETS, INSERT TOP PEG BOARD ABOVE THE BOTTOM PEG BOARD AS SHOWN.**

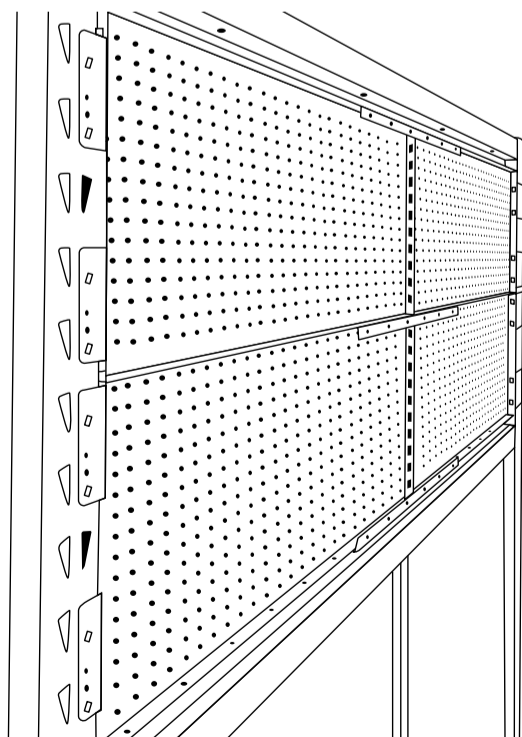

### STEP 6D

Once pegboard is in place, insert Angled Bracket in the center of the two pegboard halves and secure with supplied nuts and bolts.  
As per 5C, insert safety pins into all 4 brackets to ensure the Peg Board is secure.

